



**avenger top**  
www.avengertop.com



## Fitting Instructions for TOYOTA Hilux.MK.6-7-8 With Ladder Rack WorkStyle Edition MK.2 Double-Cab / Extra-Cab

**D** Bitte sehen Sie diese Einbau-Anleitung gründlich durch, bevor Sie mit der Montage anfangen. Garantie wird nur gewährt, wenn die Montage von einer Fachwerkstatt ausgeführt worden ist.

Änderungen hinsichtlich Ausstattung, Konstruktion, Abbildungen und Text vorbehalten.

**GB** Read this mounting manual carefully, before you start the installation. Warranty is guaranteed only when installation is done by your dealer's garage.

Modification related to design, construction, illustrations and text are reserved.

**F** Lisez cette notice de montage soigneusement avant l'illustration. Une garantie est seulement délivrée si l'installation a été exécuté par un commerçant.

Sous réserve de modifications de projet, construction, illustrations et texte.

**H** Szerelés előtt alaposan tekintse át a szerelési útmutatót. Garanciát csak abban az esetben vállalunk, ha a felépítmény felhelyezése szakmühelyben történik.

A változtatás jogát a külső, a szerkezet, a képek és a szöveg terén fenntartjuk!

**P** Leia este manual de montagem cuidadosamente, antes de iniciar a instalação. A garantia só é considerada apenas quando a montagem for efectuada por uma oficina especializada.

Com reserva de modificações relacionadas com design, construção, ilustrações e texto.

**I** Si prega di prendere attentamente visione delle presenti istruzioni di montaggio prima di procedere all'installazione dell'hardtop. La garanzia è valida solamente se il montaggio è stato eseguito da un'officina autorizzata.

Con riserva di modifiche relative alla dotazione, costruzione, immagini e testo.

**E** Lea por tanto con atención este manual (folleto) antes de que la instalación comienza. Garantía es válida solamente si la instalación de este producto fue instalada por medio de una distribuidora autorizada.

Cambios en proyecto, construcción, retrato y texto son prohibidos.

**S** Läs noggrant igenom denna monteringsanvisning innan du börjar Installationsarbetet. Garantin gäller endast då installationen är utförd av en auktoriserad verkstad eller är fackmannamässigt utförd.

Med reservation för modifieringar gällande design, konstruktion, illustrationer och text.

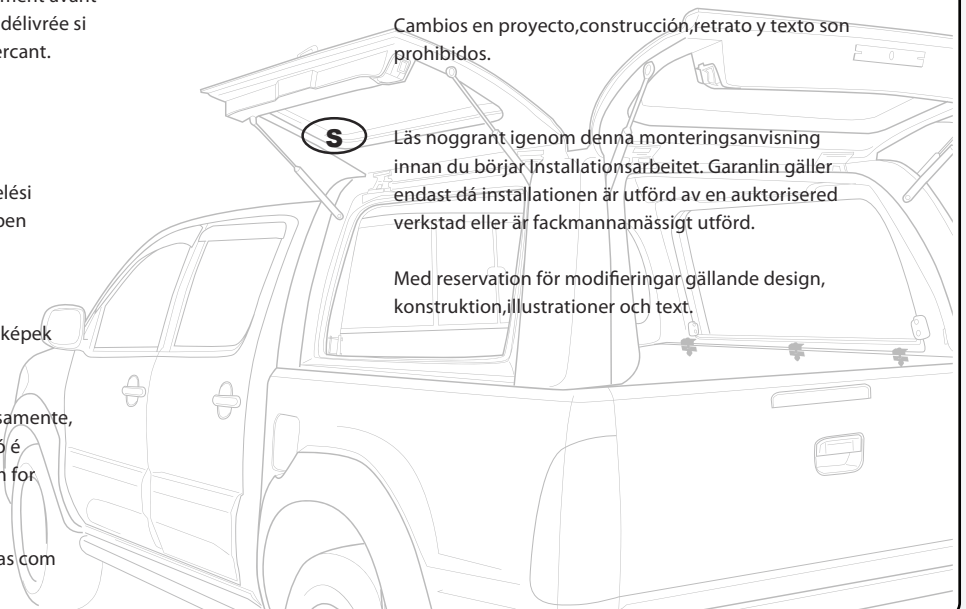

# For TOYOTA

Hilux.MK.6-7-8  
With Ladder Rack

## Double-Cab / Extra-Cab

### Required tools

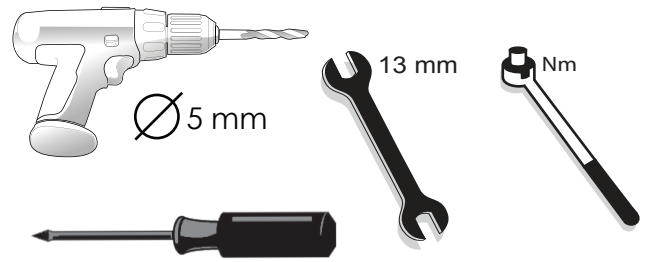

### Fitting Kit

M8 x 90 x 1.25

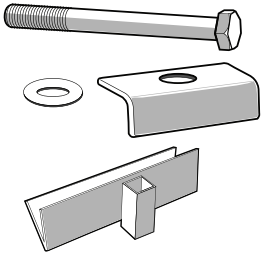

x 6

M8 x 1.25

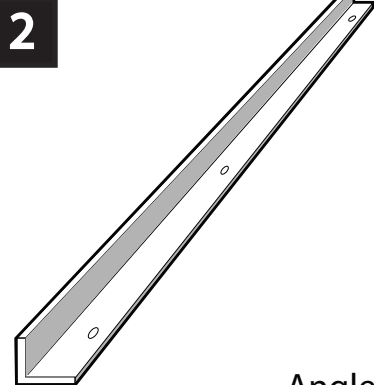

Angle Bar

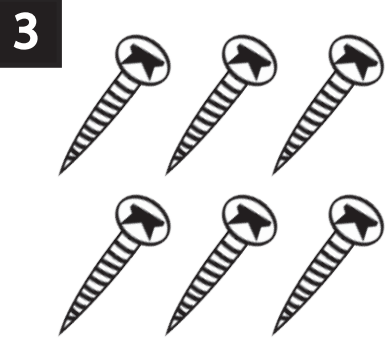

Screws 4 mm

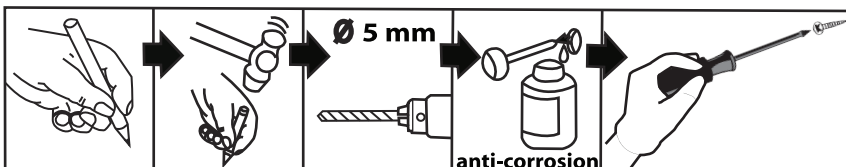
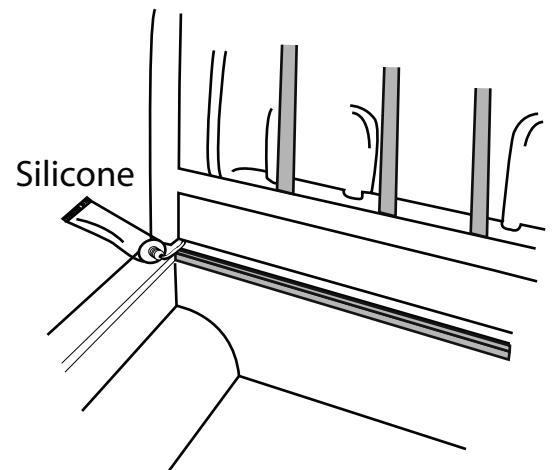
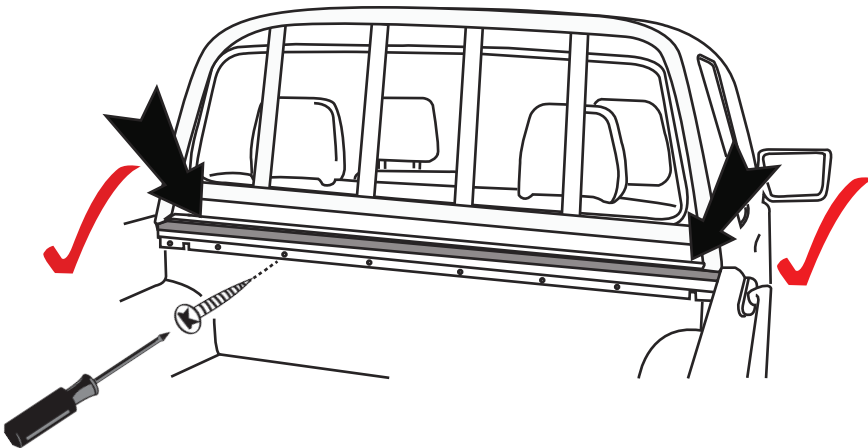
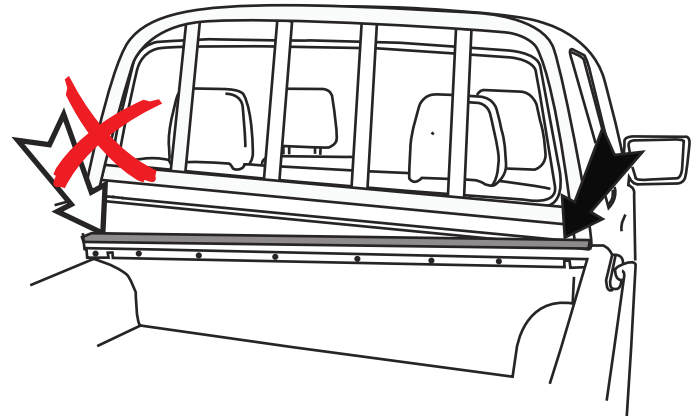
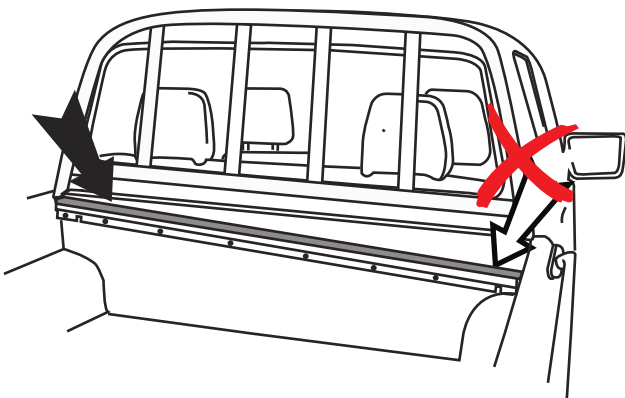



# avenger top

www.avengertop.com

## The Finest Lifestyle Truck Tops GB Fitting Instructions.

- (GB)** Fitting Instructions
- (D)** Montageanleitung
- (NL)** Montagevoorschrift
- (F)** Instructions de montage
- (E)** Instrucciones de montaje
- (I)** Schema di montaggio
- (S)** Manual
- (RUS)** руководство по монтажу



## Fitting Instructions for WorkStyle Edition MK.2 Double-Cab / Extra-Cab

### Fitting Kit

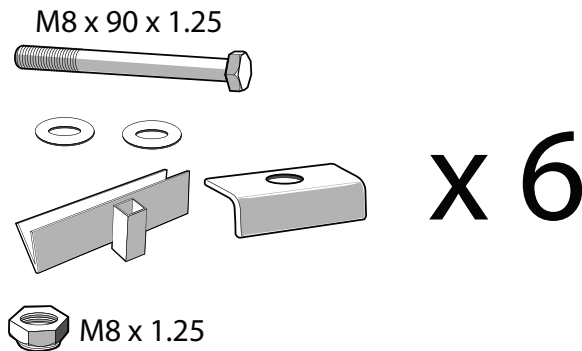

### Required tools



1) With both the vehicle's tailgate and Truck Top's tailgate closed using 2 people lift the Truck Top on to the bed. Line up, lifting the top far forward so the Truck Top's glassed rear door touches the vehicle's tailgate.

Check position around rear seal front & sides.

2) Open both tailgates & climb inside, clamp down firmly (without over tightening) in position on all six points. Check again the Alignment on the outside & check the tailgates close without fouling the rear door retaining catches may need adjusting on the inner pillars (two bolts) so as the door catches securely at both side.

#### Do not over tighten.

3) Fit the 6 oval shaped rubber grommets to cover the fittings.

4) **Fitting of the rear door corner seal** - the two shape corner rubbers are essential in ensuring the Truck Top is reasonably waterproof. Clean off the paintwork with metholated wipe or similar & adhere as illustrated. These must be adhered correctly.

5) **Wiring** – We recommend using a qualified auto-electrician:

Drill a small (approx: 8mm) hole in the driver side Rear light cluster housing.

Pass the three wires through the hole & joint to the vehicle's wiring.

Use care and **cut** the cable tie which holds the wires.

Do not pull as this will rip the head lining.

6) Check tightness of the clamps periodically.

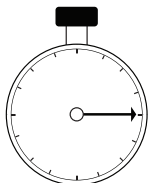

## 45 min

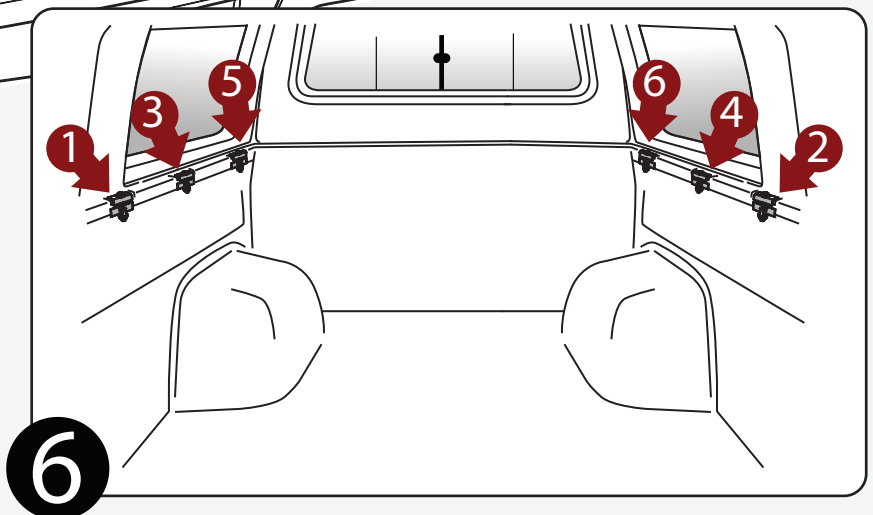
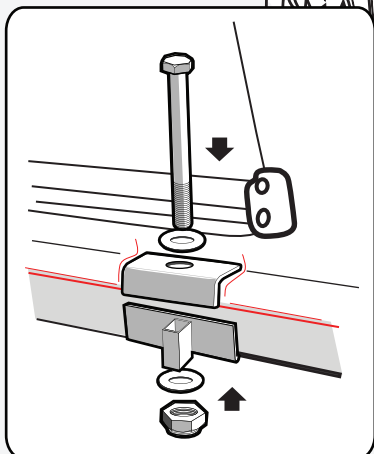
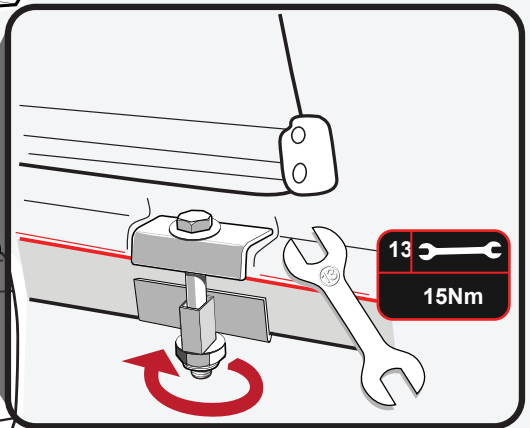
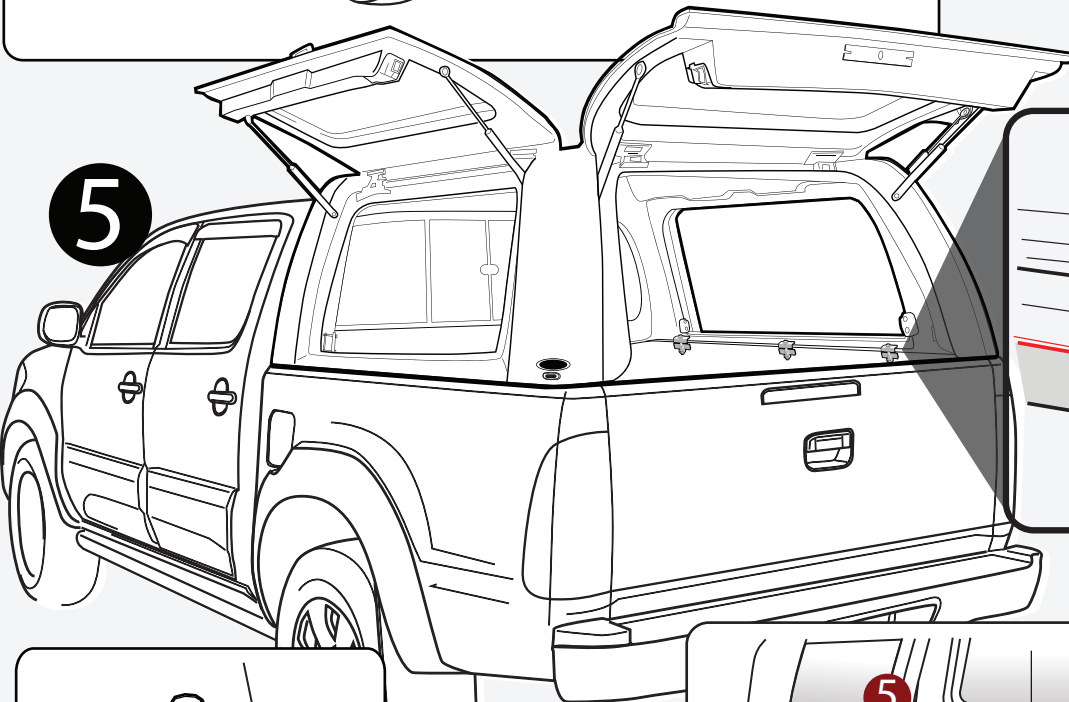
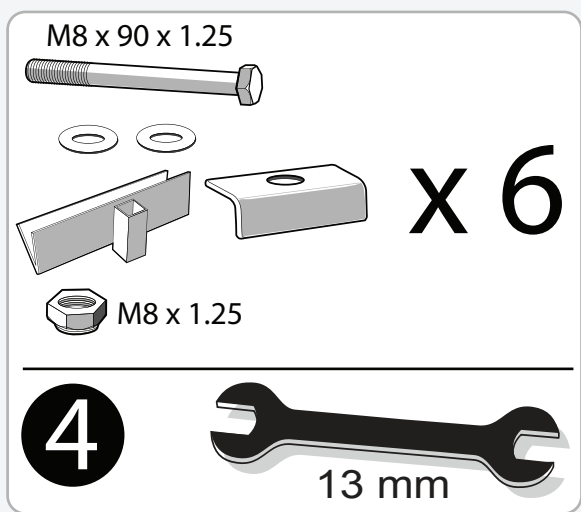
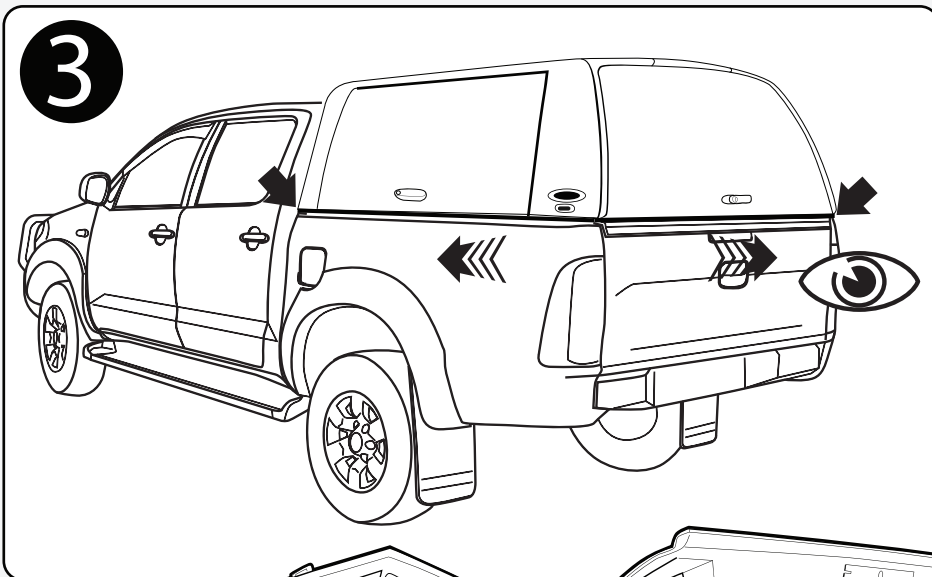
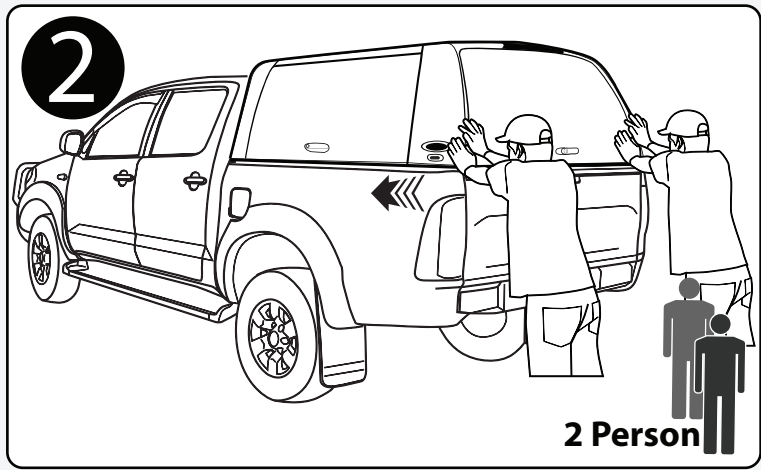
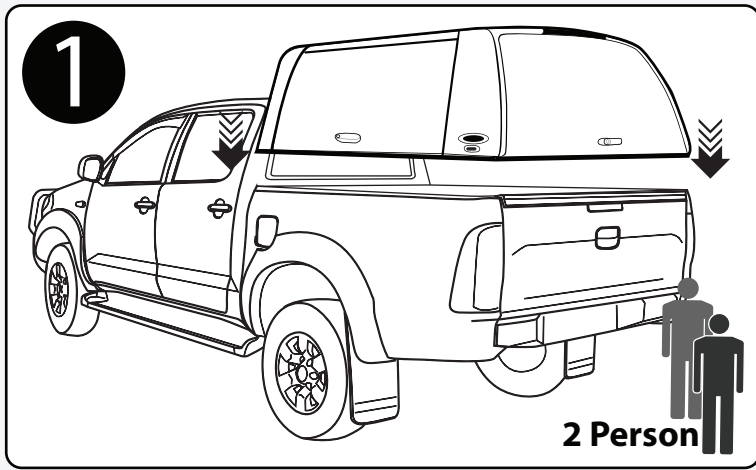



## **D** ACHTUNG!

Etwaige Gewährleistungsansprüche bzw. Schadensersatzansprüche aller Art können von uns nur bei einer ordnungsgemäßen und der Anleitung entsprechenden Montage in einer Fachwerkstätte berücksichtigt werden.

Wir weisen ausdrücklich darauf hin, daß eine unsachgemäße und nicht in einer Fachwerkstätte durchgeführte Montage einen Verzicht auf die Geltendmachung jeglicher Art insbesondere auch aus dem Titel des Produkthaftpflichtrechtes bewirkt.

Für die Befestigung sind ausschließlich die beiliegenden Befestigungsteile zu verwenden.

## **GB** ATTENTION!

Guarantee claims/compensation claims of all kinds can only be entertained by us if assembly has been carried out properly and in accordance with instructions in a specialist workshop.

We would expressly point out that any improper assembly which is not carried out in a specialist workshop will result in the renunciation of the enforcement of compensation claims of any kind, in particular those arising by virtue of the product liability law.

For the purpose of fixing, please use the attached fixing parts only.

## **F** ATTENTION!

Nous attirons votre attention sur le fait que toute réclamation ou demande en dommage et intérêt ne pourrait être formulée que tant que le montage aura été fait suivant les instructions techniques prévues pour notre produit.

Il est expressément prévu qu' on ne saurait se prévaloir d' un quelconque préjudice contractuel ou réhibitoire si le montage avait été fait en dépit des dites instructions ou dans un garage ne disposant pas des équipements adéquats.

Pour la fixation, utiliser exclusivement les éléments ci-joints.

## **E** ATENCIÓN!

Pretensiones de garantía respectivamente toda clase de reclamaciones a indemnización por danos y perjuicios pueden considerarse por nosotros solamente en caso de un montaje debidamente ejecutado en un taller especializado.

Llamamos expresadamente su atención al hecho que un montaje no apropiado y no efectuado en un taller especializado tendrá por consecuencia la renuncia al ejercicio de toda clase, sobre todo originando del título de ley sobre la responsabilidad para productos defectuosos.

Para su fijación se usarán únicamente las piezas de fijación adjuntas.

## **I** ATTENZIONE!

Prendiamo in considerazione eventuali richieste di garanzia e reclami per danni di qualsiasi genere solamente se il montaggio è stato correttamente eseguito presso un'officina autorizzata in base alle relative istruzioni.

Vi facciamo espressamente presente che il montaggio non regolare e non effettuato presso un'officina autorizzata comporterà la rinuncia di qualsiasi prestazione in garanzia, in particolare derivante dalla responsabilità del produttore.

Per il fissaggio vanno utilizzate esclusivamente le parti accluse.

## **S** OBS!

Eventuella garantieller skadestandskrav av all slag kan endast godkännas om monteringen har genomförts på aut. verkstad enligt monteringsanvisning.

Vi papekar uttryckligt att en ej lämplig eller ej på verkstad genomförd montering medför förlust av rätten att göra gallande anspråk av alla slag i synnerhet rätten ur produkt ansvarighets lagen.

För monteringen får endast de bifogade monteringsdestaljerna användas.

**H** Bármilyen jellegű esetleges garancia igényt, vagy kárpótlási igényt kizárólagosan a szakszerű és a szerelési útmutató alapján, szakmühelyben végrehajtott szerelés esetén tudunk elfogadni.

Külön figyelmeztetjük, hogy a nem szakszerű és nem szakmühelyben végzett szerelés minden jellegű garancia igényről való lemondást von maga után, egyben megszűnik a termék szavatossági joga.

A rögzítéshez kizárólag a mellékelt alkatrészeket kell alkalmazni.

## **P** Atenção

Reclamações de garantias / indemnizações de garantias de todas as formas podem apenas ser consideradas por nós se a montagem tiver sido efectuada adequadamente por uma oficina especializada.

Salientamos expressamente que qualquer montagem impropria que não tenha sido efectuada por uma oficina especializada resultará na renuncia de aceitação de qualquer reclamação, em particular, reclamações por defeito de produto.

Para fixação, usar apenas as peças de fixação anexas para o efeito.

